

NEW BRIGHT

OWNER'S MANUAL

Please read and understand all precautions prior to use.

Thank you for choosing a premium New Bright product.

REF- PB90216 1202

JN119-21

CONTENTS

Component Checklist

- (1) R/C Vehicle With USB Cord
- (1) Transmitter
- (2) AA Batteries

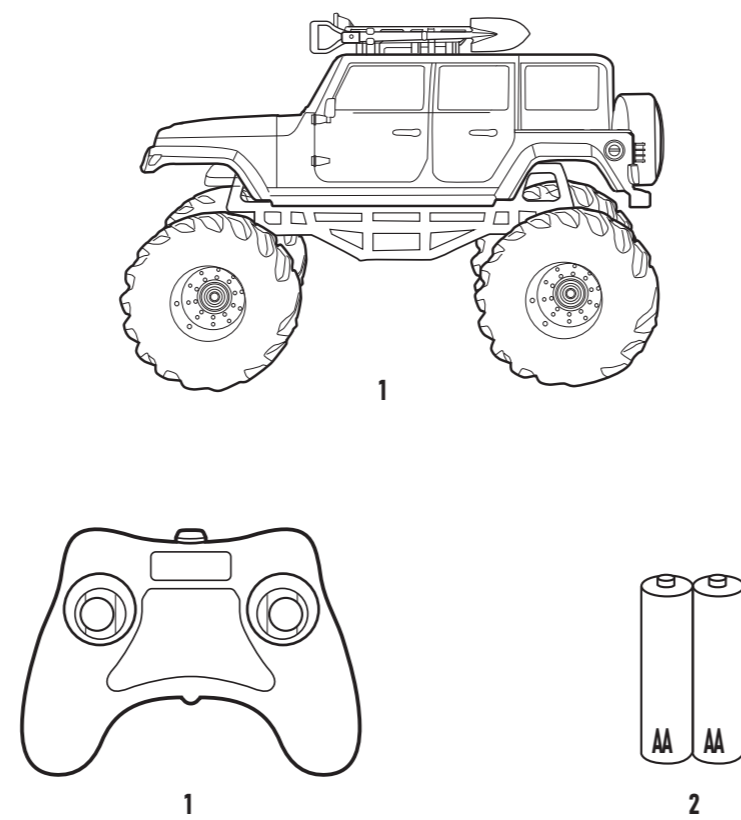

VEHICLE

Features

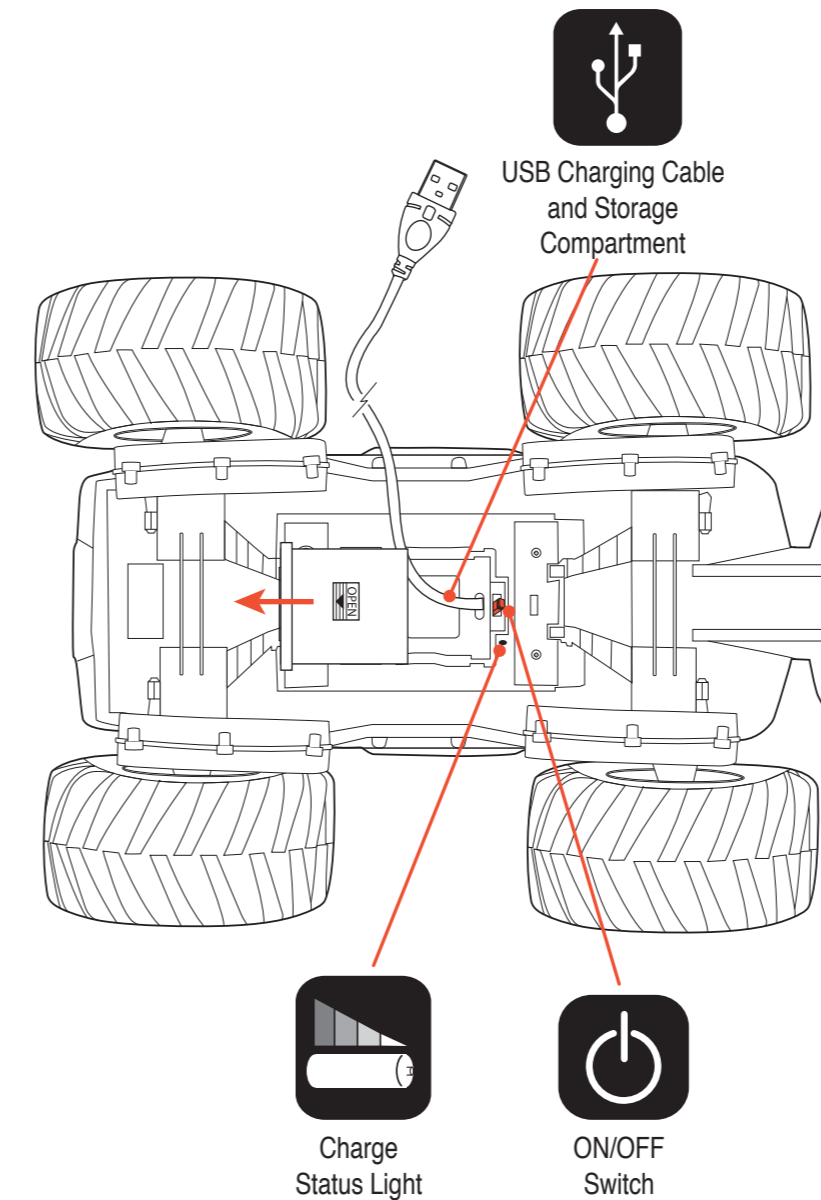

The ON/OFF Switch controls the main power to the vehicle. To save battery life, always remember to put switch in the OFF position when not in use.

BATTERY

USB Smart Charge Technology

This product is equipped with USB Smart Charge Technology. The built-in "smart chip" can recognize the power output level of your chosen USB charging device. Charge times will vary between charging devices. Charging from a wall outlet with a USB adapter may be faster than charging from a USB port on a computer. Using Advanced USB Power Delivery, the smart chip will charge the vehicle's internal battery at the fastest speed allowed by your charging device.

Charging the Vehicle

This vehicle is equipped with an internal Lithium-Ion battery that is recharged via USB. **ON/OFF Switch must be in the OFF position prior to charging.**

1. Locate the ON/OFF switch and USB cord on the under-side of the vehicle.
2. Turn the ON/OFF switch to the "OFF" position.
3. Slide open Storage Compartment cover.
4. Remove USB cable from the Storage Compartment. (Use care when extending cord as it is attached to inside internal battery). Cord can be plugged into any computer or USB outlet adapter (not included).

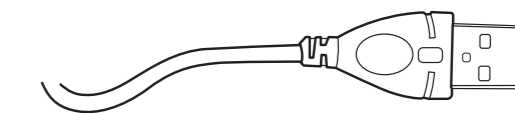

5. While charging, the LED under the vehicle will be on. Once fully charged the LED will turn off. Charging is completed in approximately 1 - 1.5 hours depending on the type of charging device you use. Return cord and secure storage lid before operating the vehicle.

TRANSMITTER

Features and Functions

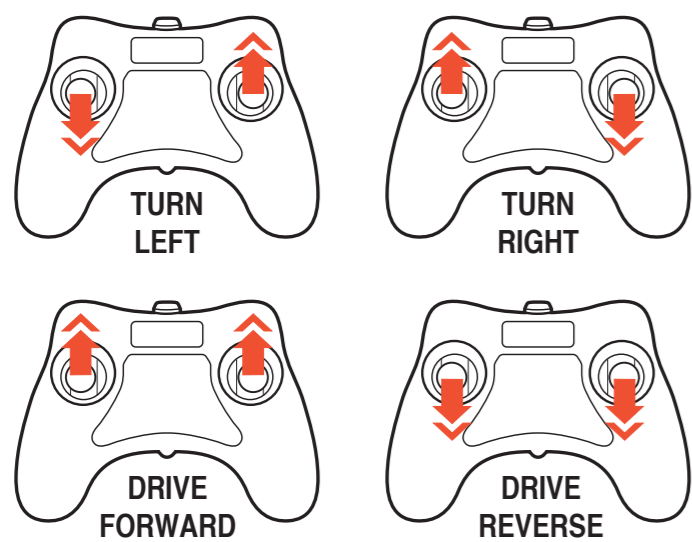

FORWARD/REVERSE DRIVING
Push BOTH joysticks forward for Forward Driving.
Pull BOTH joysticks back to drive in Reverse.

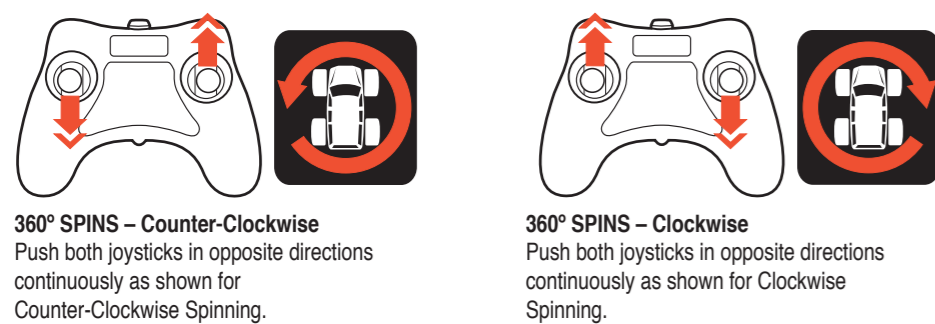

This transmitter is equipped with 2.4GHz technology which allows up to 6 vehicles to be raced at the same time.

The transmitter will automatically sync with the vehicle.

TRANSMITTER

Battery Installation

1. Locate the Transmitter Battery Compartment, which is on the back of the Transmitter.
2. Move the Battery Compartment Lock towards the Battery Compartment and remove the Battery Compartment Cover.
3. Insert 2 "AA" batteries. Make certain the plus (+) and minus (-) markings on the batteries are in the same position as the plus (+) and minus (-) markings inside the Battery Compartment.
4. Replace Battery Compartment Cover making certain that the Battery Compartment Lock has "snapped" into the locked position.

Note: When replacing batteries:
Use alkaline batteries only.
Do not mix old and new batteries.
Do not mix alkaline, standard or rechargeable batteries.

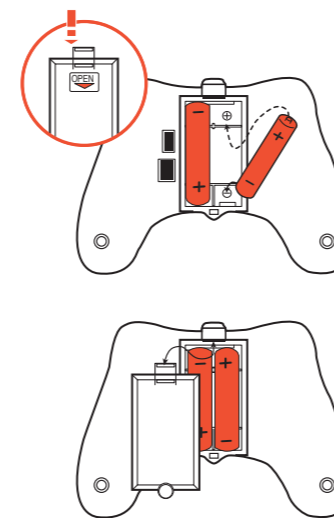

Precautions and Care

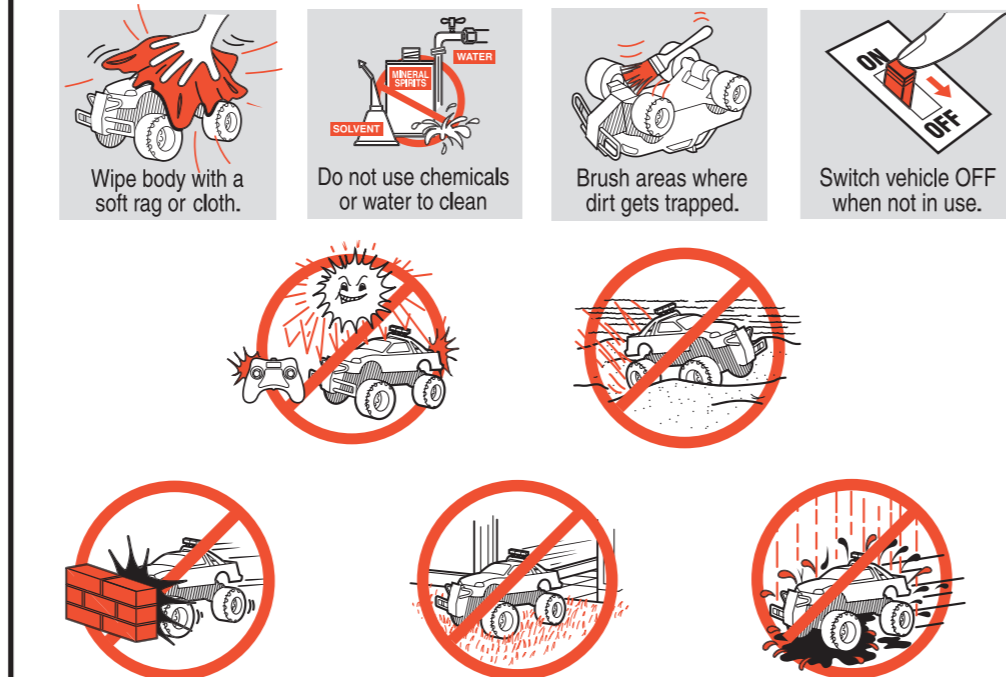

SUPPORT

Trouble shooting & Support

Problem - Vehicle does not move or moves slowly.

- Make certain there are fresh batteries in the transmitter and that they have been installed in the correct position.
- Are the (+) and (-) markings on the batteries in the same position as the (+) and (-) markings in the Transmitter Battery Compartment?
- Are the metal contact tabs touching, rusty or dirty in the transmitter?
- Has the rechargeable Internal Battery been fully charged?
- Make certain that the vehicle ON/OFF switch is in the "ON" position.

Problem - Vehicle moves by itself or exhibits reduced range from the transmitter.

- Make certain there are no outside radio interference in your area. The best way to test this is to take the vehicle as far away from radio towers, electrical lines or tall buildings as possible to ensure no further radio interference will occur.

Always remove Batteries from transmitter when not in use.

Do not dispose batteries in fire. Leakage, explosion and personal injury may occur.

Do not attempt jumps or tricks with this vehicle.

Do not attempt to remove internal battery.

Do not use included USB cord for anything other than its intended purpose.

Always keep USB cord stored when not in use.

Adult supervision recommended.

F.C.C. CAUTION:

Changes or modifications not expressly approved by the party responsible for compliance could void the user's authority to operate the equipment.

This device complies with Part 15 of the FCC Rules. Operation is subject to the following two conditions:
(1) this device may not cause harmful interference, and (2) this device must accept any interference received, including interference that may cause undesired operation.

NOTE:

This equipment has been tested and found to comply with the limits for a Class B digital device, pursuant to Part 15 of the FCC Rules. These limits are designed to provide reasonable protection against harmful interference in a residential installation. This equipment generates, uses and can radiate radio frequency energy and, if not installed and used in accordance with the instructions, may cause harmful interference to radio communications. However, there is no guarantee that interference will not occur in a particular installation. If this equipment does cause harmful interference to radio or television reception, which can be determined by turning the equipment off and on, the user is encouraged to try to correct the interference by one or more of the following measures:

- Reorient or relocate the receiving antenna.
- Increase the separation between the equipment and receiver.
- Connect the equipment into an outlet on a circuit different from that to which the receiver is connected.
- Consult the dealer or an experienced radio/TV technician for help.

USA & Canada 30-Day Limited Warranty

New Bright Industries warrants to the original purchaser that this product will be free of defects in materials and workmanship for thirty (30) days from the date of purchase. In the event of such defect within the warranty period, New Bright will repair or replace the product at our sole discretion. This warranty does not cover damage resulting from unauthorized modifications, accident, misuse or abuse.

Should your item have a defect covered under this warranty, first call the toll free number listed below. Most problems can be resolved in this manner. If necessary, you will be issued a Return Authorization (RA) number and instructions on how to obtain a Product Return Form. The Product Return Form is to be used when returning a product to us (postage pre-paid and insured by the consumer).

When returning a defective product, please package the product, the Product Return Form and a copy of the dated sales receipt as proof of purchase. Be sure to mark the RA number on the Product Return Form. If the product is returned without a dated sales receipt, it will be excluded from coverage under this warranty. Please allow 4 to 6 weeks for delivery of repaired or replacement vehicles (depending on your location).

New Bright Industries' liability for defects in materials and workmanship under this warranty shall be limited to repair or replacement at our sole discretion. In no event shall we be responsible for incidental, consequential or contingent damages (except in those states that do not allow this exclusion or limitation).

Valid only in the USA & Canada.

Contact New Bright Industries Customer Service Toll Free at:
1-877-NBI-TOYS
(1-877-624-8697)
Monday through Friday, 8:00 AM to 5:00 PM Eastern Time

U.S. Toy Sales and Marketing Co. Inc.
30260 Oak Creek Drive - 2nd Floor
Wilcom MI 48393
1-877-624-8697
<http://www.newbright.com/>